

Standard and White LED Basics and Operation

For many years the light emitting diode (LED) has been a popular choice for use in status displays and matrix panels. Now, you can choose among recently developed blue and white types (widely used in portable devices) as well as the ubiquitous green, red, and yellow types. White LEDs, for instance, are considered ideal background illumination for colored displays. But, you should note the inherent peculiarities of these new LED devices when designing power supplies for them. This article describes the properties of old and new LEDs, and performance required for power sources that activate them.

Standard Red, Green, and Yellow LEDs

The simplest way to operate an LED is to apply a voltage source across it with a resistor in series. The LED emits constant-intensity light as long as the operating voltage (V_B) remains constant (although the intensity decreases with increasing ambient temperature). You can vary the light intensity as required by changing the resistor value.

For a standard LED of 5mm diameter, Figure 1 shows the forward voltage (V_F) vs. forward current (I_F). [1] Note that the voltage drop across an LED increases with forward current.

Assuming that a single green LED with 10mA forward current should have a constant operating voltage of 5V, the series resistor R_V equals $(5V - V_{F,10mA})/10mA = 300\Omega$. The forward voltage is 2V, as indicated by a graph of typical operating conditions found in the data sheet (Figure 2).

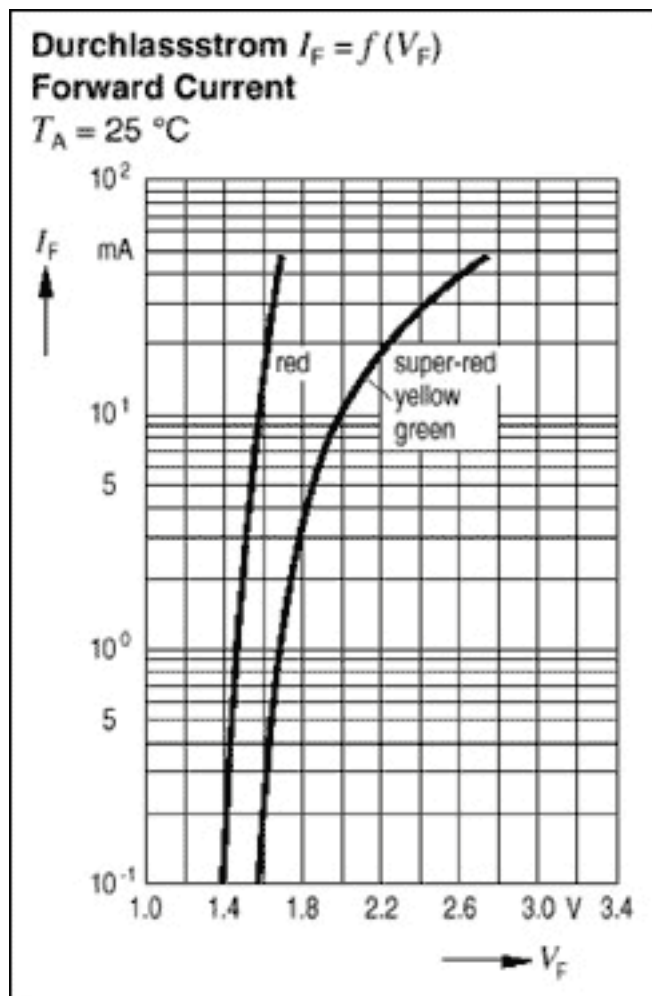

Figure 1. Standard red, green, and yellow LEDs have forward voltages in the range 1.4V to 2.6V, depending on the desired brightness and the choice of forward current. For forward currents below 10mA, the forward voltage varies only a few hundreds of millivolts.

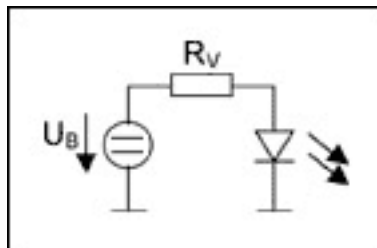

Figure 2. A series resistor and constant-voltage supply provides a simple way to operate an LED.

Commodity diodes like this one are produced with a gallium-arsenide-phosphid combination. Easy to handle and known to most design engineers, they provide lots of advantages:

- The emitted color (emitted wave length) remains relatively constant with variations in the forward current, operating voltage, and ambient temperature. Standard green LEDs emit a wavelength of about 565nm, with a small tolerance of only 25nm. Operating several such LEDs in parallel does not present a problem (Figure 3) because color differences are very small. The normal variation in forward voltages produces slight differences in light intensity, but those are also minor. You can usually neglect any differences among

LEDs from the same manufacturer and lot.

- Forward voltages show little change with forward current up to approximately 10mA. The variation is about 200mV for red LEDs and about 400mV for other colors (Figure 1).
- For forward currents below 10mA, the forward voltage is much less than for blue or white LEDs, which allows inexpensive operation directly from a Li+ cell or a triple NiMH cell.

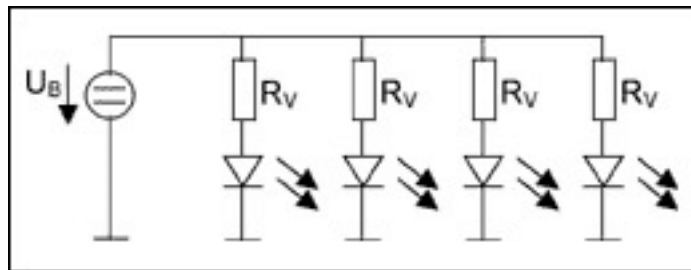

Figure 3. The configuration shown operates several red, yellow, or green LEDs in parallel, with very little color difference or variation in brightness.

Thus, the cost of electricity for operating standard LEDs is quite low. Boost converters or complicated and expensive current sources are unnecessary if the LED's operating voltage is higher than its maximum forward voltage.

These LEDs can even operate directly on Li+ or triple NiMH cells, as long as the application can tolerate decreasing light intensity as the battery cells discharge.

Blue LEDs

LEDs that emit blue light were unavailable for a long time. Design engineers only could fall back on the existing colors red, green and yellow. Early "blue" devices were not actually blue LEDs, but small incandescent bulbs surrounded with a blue-colored diffuser.

The first "true blue" LEDs were developed several years ago using a pure silicon carbon material (SiC), but their light efficiency was poor. The next-generation devices had a gallium-nitride base material that achieved light efficiencies several times that of the first versions. Today's epitaxy material for blue LEDs is called Indium-Gallium-Nitride (InGaN). Emitting wavelengths in the range 450nm to 470nm, InGaN LEDs produce five times the light intensity of gallium-nitride LEDs.

White LEDs

True white-light-emitting LEDs are not available. Such a device is difficult to build because LEDs typically emit one wavelength. White does not appear in the spectrum of colors; instead, perceiving white requires a mixture of wavelengths.

A trick is employed to make white LEDs. Blue-emitting InGaN base material is covered with a converter material that emits yellow light when stimulated by the blue light. The result is a mixture of blue and yellow light that is perceived by the eye as white (Figure 4). [2]

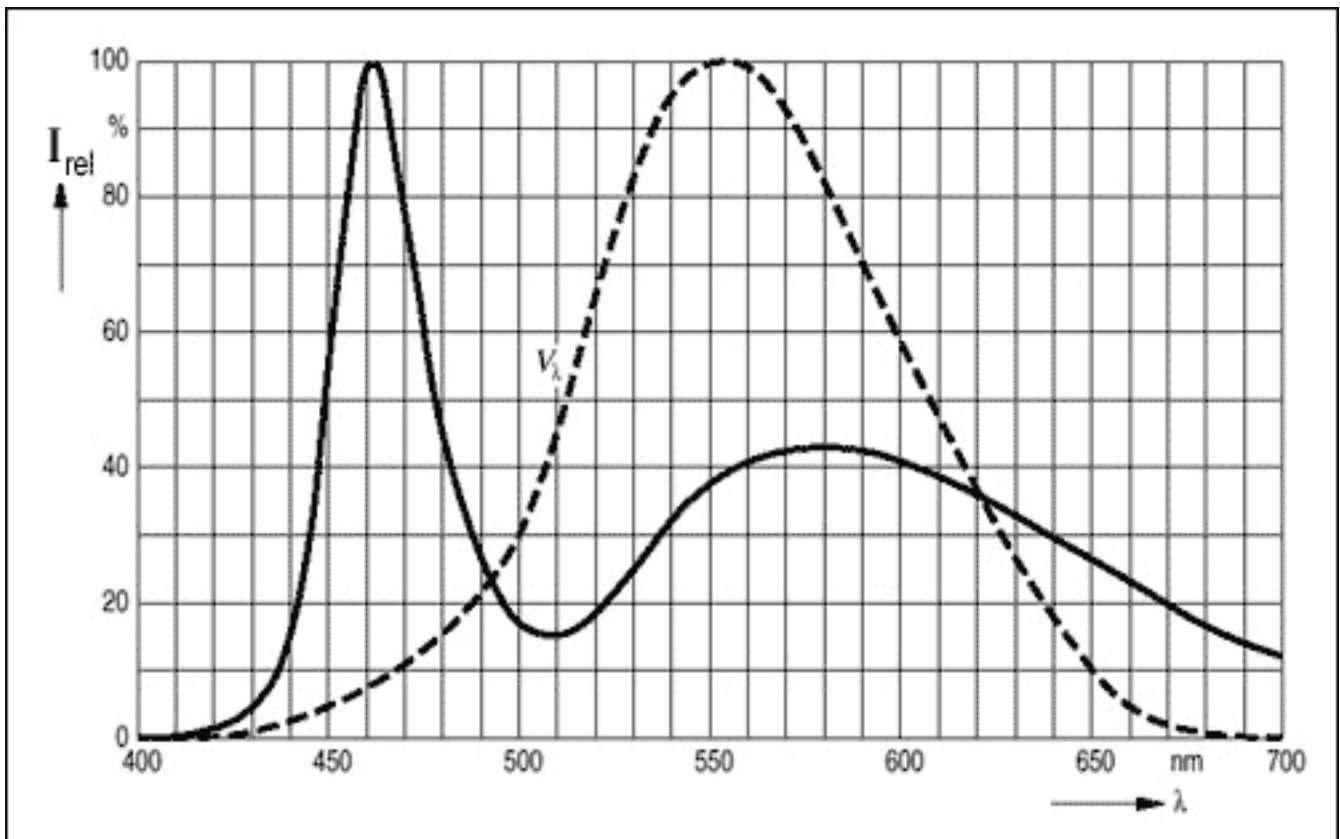

Figure 4. The emitted wavelengths of a white LED (solid curve) include peaks in the blue and yellow areas, but are interpreted as white light by the human eye. The relative light sensitivity of a human eye (dotted curve) is shown for comparison.

The color of a white LED is defined by color coordinates. Values for these X and Y coordinates are calculated according to instructions found in publication 15.2 of the Commission Internationale De L'Eclairage (CIE). [3] The data sheets for white LEDs often specify a change of these color coordinates with increasing forward current (Figure 5). [4]

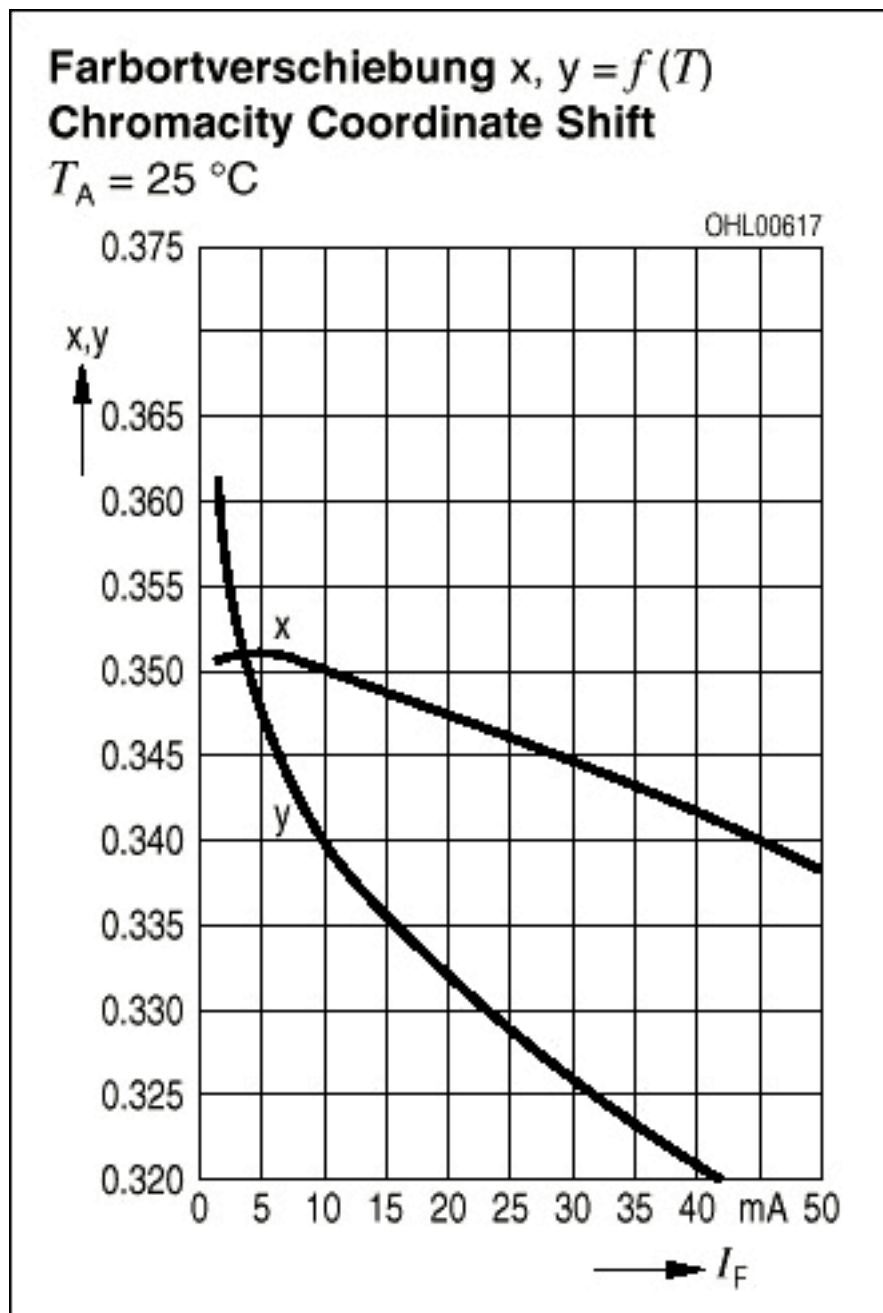

Figure 5. A change in forward current shifts the chromaticity coordinates of a white LED (an LE Q983 from OSRAM Opto Semiconductors), and hence the quality of its white light.

Unfortunately, InGaN-technology LEDs are not as easy to handle as are the standard green, red and yellow types. The dominant wavelength (color) of an InGaN LED changes with the forward current (Figure 6). White LEDs, for example, exhibit a color shift due to different concentrations of converter material, in addition to a change of wavelength with forward voltage for the blue-emitting InGaN material. That color change can be seen in Figure 5, where a shifting of the X- and Y-coordinates means a color change. (As mentioned earlier, white LEDs have no specific wavelength.)

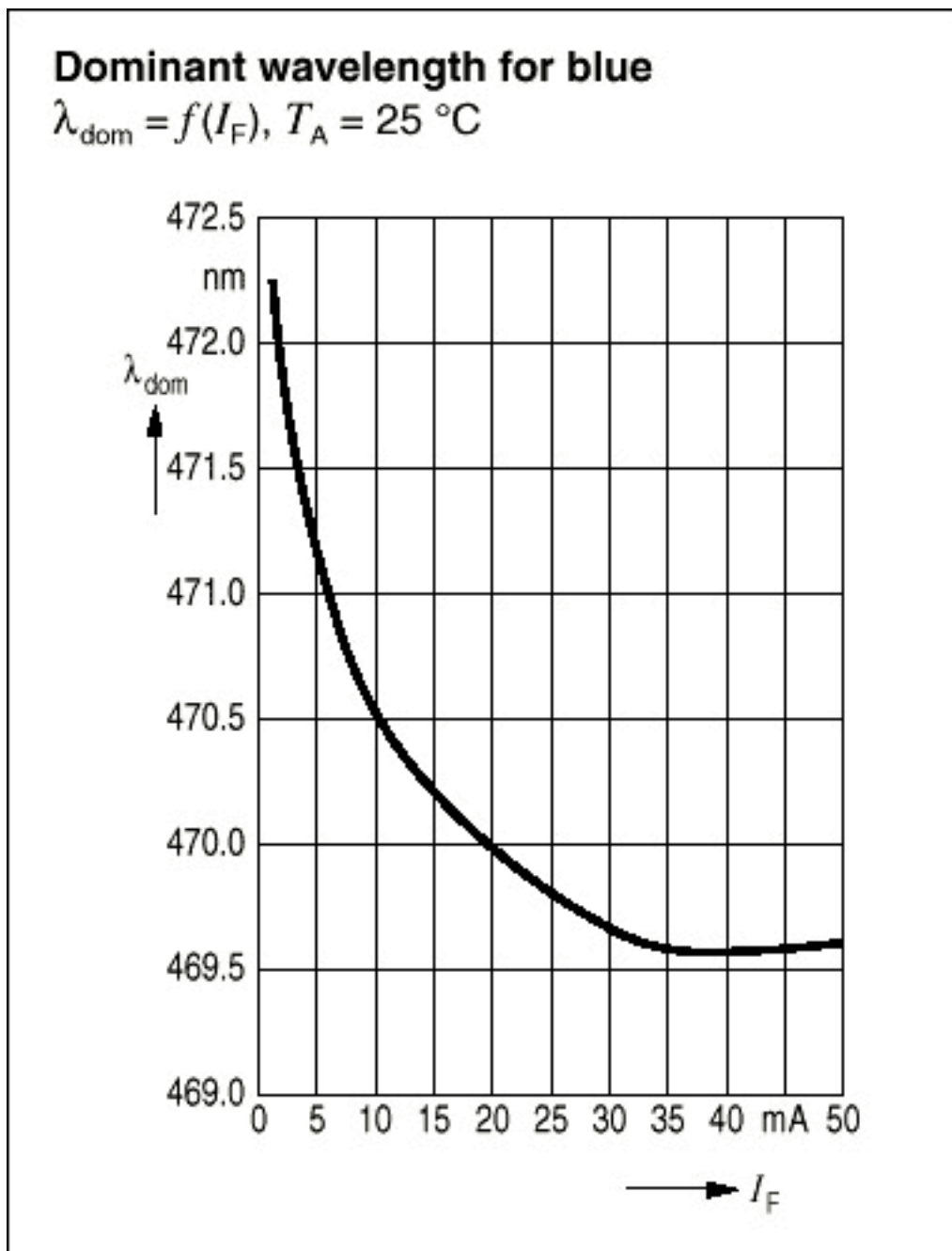

Figure 6. An increasing forward current changes the tint of a blue LED by changing its emitted wavelength.

Forward voltage changes greatly for forward currents up to 10mA. The range of variation is about 800mV (some diode types change even more). A change in operating voltage caused by battery discharge therefore changes the color, because a change in operating voltage changes the forward current. At a forward current of 10mA the forward voltage is about 3.4V (this quantity varies with the manufacturer, and ranges from 3.1V to 4.0V). The current-voltage characteristic also exhibits a strong variation from LED to LED (see below). Operating the LED directly from a battery is difficult, because the discharged state of most batteries is below the LED's minimum-required forward voltage.

Operating White LEDs in Parallel

Many portable and battery-operated devices use white LEDs for background illumination. In particular, the colored displays of PDAs need a white backlight to obtain color reproduction that is close to the original. Future 3G mobile phones will support picture and video data, which require white backlight illumination. Digital still cameras, MP3 players, and other video and audio equipment also include displays that require a white backlight.

In most cases a single white LED is not sufficient, so several must be operated together. Special steps must be taken to make sure their intensity and color is matched, even as battery charge and other conditions vary.

Figure 7 shows the current-voltage curves from a group of randomly selected white LEDs. Applying a voltage of 3.3V to these LEDs (upper dotted line) produces forward currents in the range 2mA to 5mA, which in turn produces different shades of white color. The Y coordinate in particular changes strongly in this area (Figure 5), resulting in a non-true reproduction of color in the illuminated display. The LEDs also have different light intensities, which produces inhomogeneous illumination. Another problem is the required minimum supply voltage. A voltage well above 3V is necessary for operating the LEDs. Below that level, several LEDs may remain completely dark.

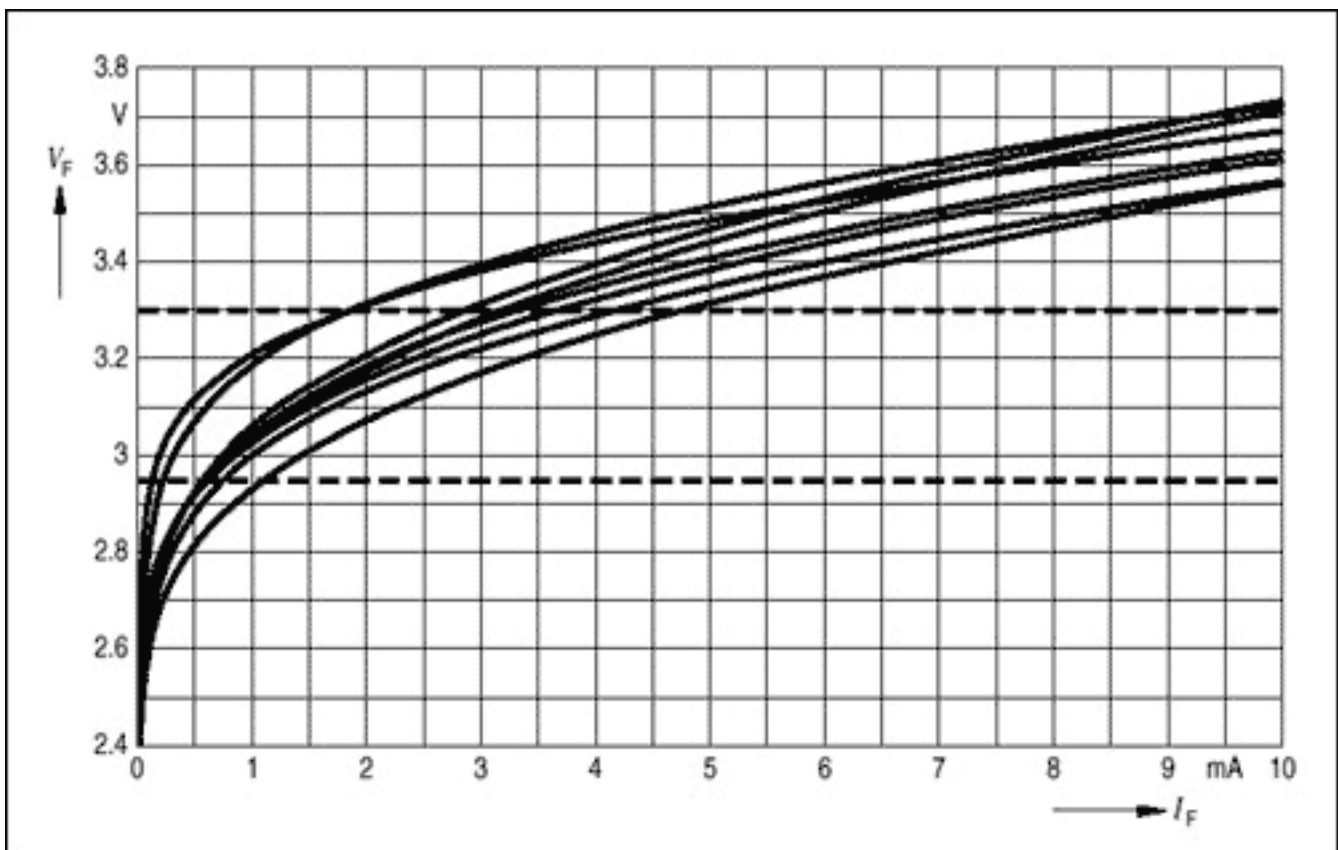

Figure 7. These curves illustrate the considerable differences in current-voltage characteristics for white LEDs, even those randomly selected from the same production lot. Operating several such LEDs in parallel at a constant 3.3V (the upper dotted line) therefore produces different shades of white and different brightnesses.

A Li-Ion battery when fully charged provides an output voltage of 4.2V, which drops to a nominal 3.5V after a short period of operation. That voltage further declines to 3.0V as the battery discharges. If white LEDs are operated directly from the battery as shown in Figure 3, the following problems occur:

At first, when the battery is fully charged, all diodes are illuminated but with different shades of light intensity and color. As battery voltage drops to its nominal level, the light intensities decrease and the differences in white become stronger. The designer must therefore consider the value of battery voltage and diode forward voltage for which the series resistor is calculated. (With a completely discharged battery, some LEDs will be completely dark.)

Charge Pump with Current Control

The goal of an LED power supply is to provide a sufficiently high output voltage, and to force the same current through all LEDs connected in parallel. Note (Figure 5) that if all the white LEDs of a parallel configuration have identical currents, all will have the same chromacity coordinates. Maxim offers a charge pump with current control for that purpose (MAX1912).

In the parallel configuration of three LEDs shown in Figure 8, the charge pump is a large-scale type that increases the input voltage by a factor of 1.5. Earlier charge pumps simply doubled the input voltage, but this new technique provides better efficiency. The input voltage is boosted to a level that just allows operation of the LEDs. Resistor networks connected to SET (pin 10) ensure identical currents in all LEDs. Internal circuitry maintains the SET voltage at 200mV, so the current through any LED can be calculated as $I_{LED} = 200\text{mV}/10\Omega = 20\text{mA}$. If some diodes require lower levels of current, you can operate more than three in parallel because the MAX1912 delivers as much as 60mA. See the MAX1912 data sheet for further applications and schematics[5].

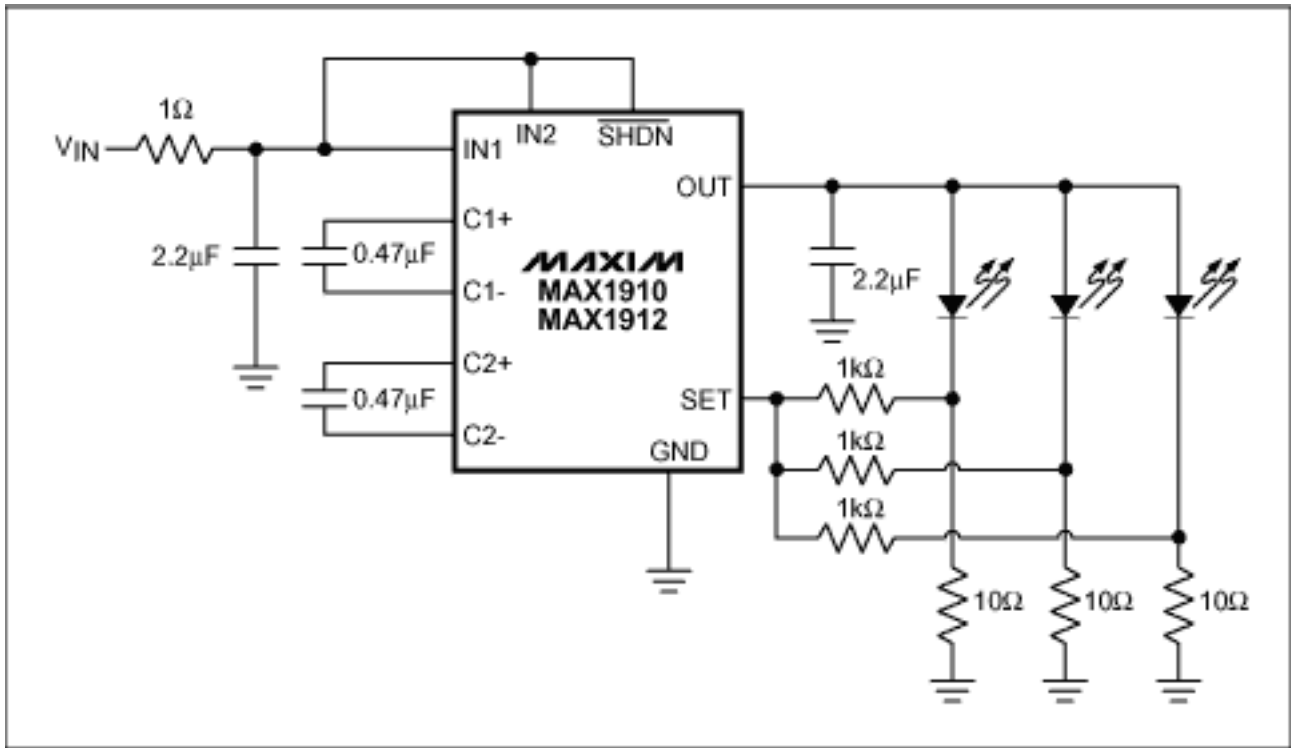

Figure 8. This IC combines a charge pump with current control. The charge pump provides sufficient operating voltage for the white LEDs, and current control ensures homogeneous white light by forcing identical currents through each LED.

Simple Current Control

White LEDs can be operated easily if the system provides a voltage higher than the forward voltage of the diodes. Digital still cameras, for example, usually include a +5V supply. In that case you don't need a boost function, because the supply voltage includes enough margin to drive the LEDs. For the Figure 8 circuit, a matched current source should be chosen. As an example, the MAX1916 can drive as many as three LEDs in parallel (Figure 9).

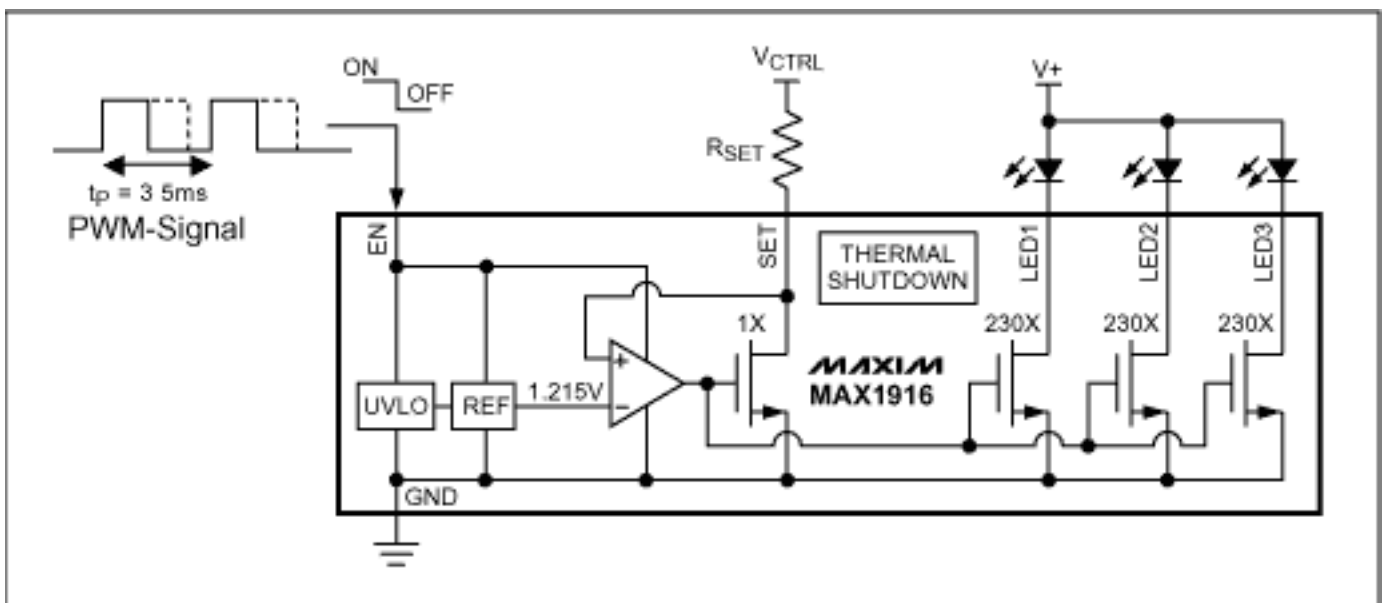

Figure 9. A single external resistor (R_{SET}) programs the value of the identical currents applied to each LED. Applying a pulse-width-modulated signal to the enable pin (EN) of this IC produces a

simple brightness control (dimming function).

The operation is simple: Resistor R_{SET} programs the current that is forced through the connected LEDs. This approach occupies very little board space. Besides the IC (a small, 6-lead SOT23 package) and a few bypass capacitors, it requires only one external resistor. The IC offers an excellent current matching of 0.3% between the LEDs. This configuration provides identical chromacity locations, and therefore identical types of white light from each LED.

Dimming Varies Light Intensity

Some portable devices control the intensity of their light output according to the ambient light conditions, and others lower the light intensity via software, after a short standby interval. Both of those operations require that the LEDs be dimmed, and such a dim function should affect each forward current in the same way to avoid possible shifts in chromacity coordination. That uniformity can be achieved with a small digital-to-analog converter that controls current through the R_{SET} resistor.

A converter of 6-bit resolution like the MAX5362, with I²C-compatible interface, or the MAX5365, with an SPI-compatible interface, makes possible a dim function with 32 steps of light intensity (Figure 10). The type of white light from the LEDs changes with a change in brightness, because forward current influences the chromacity coordinates. That should not be a problem, because identical forward currents cause each diode in the group to emit identical light.

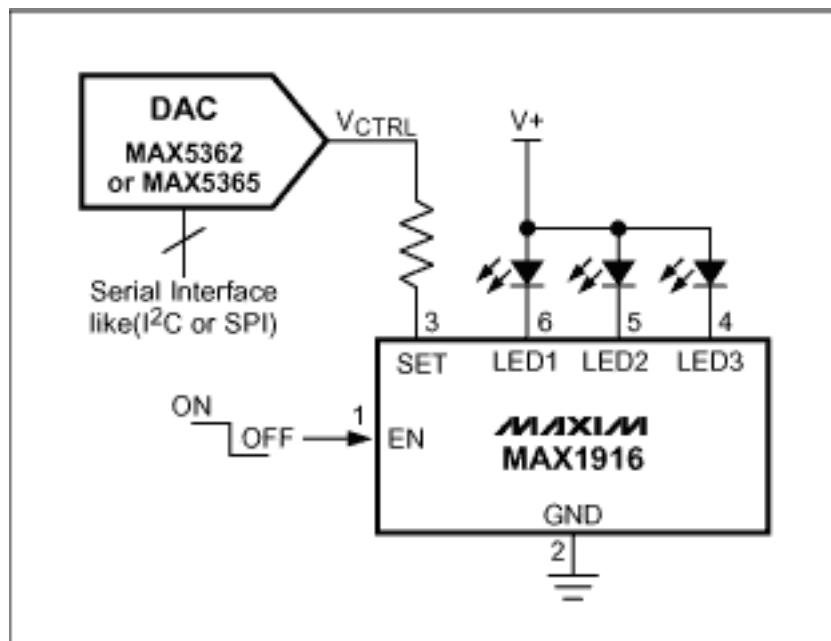

Figure 10. This D/A converter controls dimming of the LEDs by varying their forward currents in unison.

A dim function for which the chromacity coordinates do not move is called pulse-width modulation. It can be realized with most power-supply devices that provide an enable or shutdown function. The MAX1916, for example, restricts leakage current through the LEDs to a

mere $1\mu\text{A}$ as soon the part is disabled by pulling EN low. The result is zero light emission. Pulling EN high directs the programmed forward current through the LEDs. If you apply a pulse-width-modulated signal to EN, the brightness is proportional to that signal's duty cycle.

The chromacity coordinates do not move because each LED continues to see the same forward current. The human eye, however, perceives the change in duty cycle as a change of brightness. Frequencies above 25Hz are not resolved by the human eye, so a switching frequency of 200-300Hz is a good choice for PWM dimming. Higher frequencies can cause problems, because the chromacity coordinates can shift during the brief interval required for switching the LEDs on and off. A PWM signal can be provided from a microprocessor's I/O pin or one of its peripheral devices. The number of brightness steps available depends on the width of the counter register used for that purpose.

Switched-Mode Boost Converter Has Current Control

Besides the charge pump mentioned above (MAX1912), you can also implement a boost converter with current control. The MAX1848 switched-mode voltage converter, for instance, generates output voltages up to 13V—enough to drive as many as three LEDs in series (Figure 11). That approach is probably the cleanest, because all LEDs in series have exactly the same current. The LED current is determined by R_{SENSE} and by voltage applied to the CTRL input.

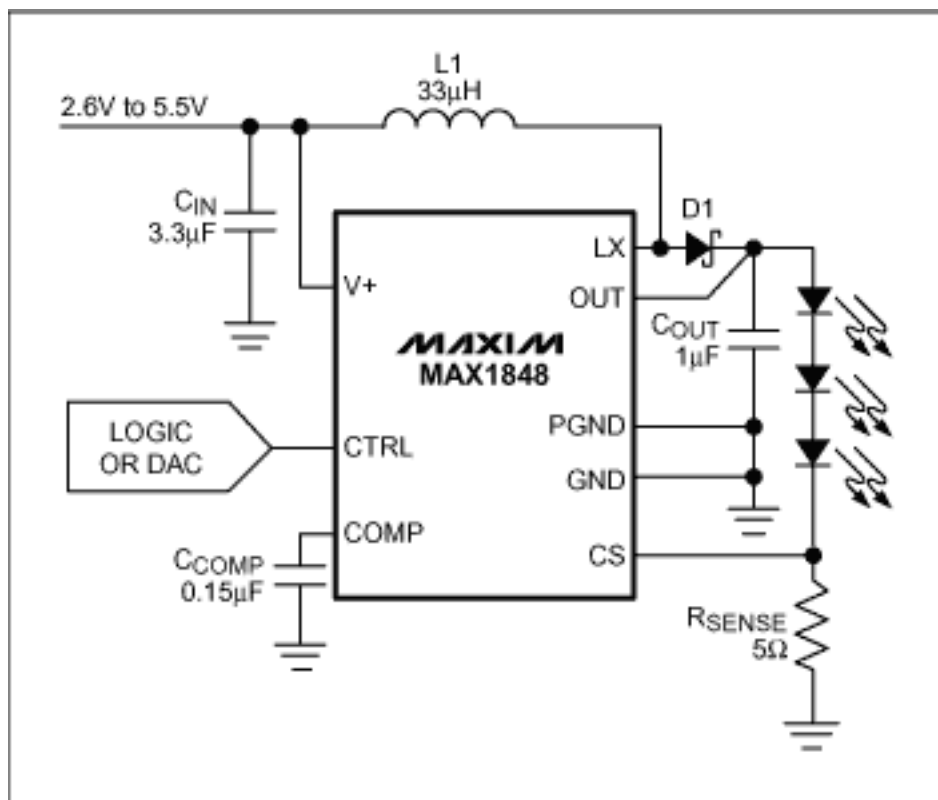

Figure 11. This switched-mode boost converter enables the operation of several LEDs in series. All have the same forward current, which is controlled via the CTRL input by (for example) a D/A converter.

The MAX1848 can implement a dimming function according to either of the methods described

above. Forward current through the LEDs is proportional to the voltage applied to the CTRL pin. Because the MAX1848 goes to shutdown mode when the voltage applied to CTRL goes below 100mV, you can also realize a PWM dim function.

Summary

White LEDs can be operated in parallel if you take care to ensure the emission of homogeneous white light by making their forward currents equal. To operate the LEDs, choose either a controlled current source or a combination of step-up converter with current control. Using charge pumps or switched boost converters, you can implement such combinations with a few standard products.

Literature

[1] Data Sheet "LR5360, LS5360, LY5360, LG5360", OSRAM Opto Semiconductors, Regensburg, 2001.

[2] "Driving InGaN-Based LED in Parallel Circuits," Gerhard Scharf, OSRAM Opto Semiconductors, November 2001.

[3] Colorimetry, 2nd Edition, Publication CIE 15.2-1986, ISBN 3 900 734 00 3.

[4] Data Sheet "Hyper ChipLED LW Q983," OSRAM Opto Semiconductors, Regensburg, 2001.

[5] Data Sheet MAX1912, Maxim Integrated Products, 2002: <http://www.maxim-ic.com/max1912>.

More Information

MAX1848: [QuickView](#) -- [Full \(PDF\) Data Sheet](#) -- [Free Samples](#)

MAX1912: [QuickView](#) -- [Full \(PDF\) Data Sheet](#) -- [Free Samples](#)

MAX1916: [QuickView](#) -- [Full \(PDF\) Data Sheet](#) -- [Free Samples](#)